



8+



4



2,4m



1 = 5,24m
2 = 1,09m
3 = 2,93m



Motorische Einschränkung



Sensorische Einschränkung



Kognitive Einschränkung

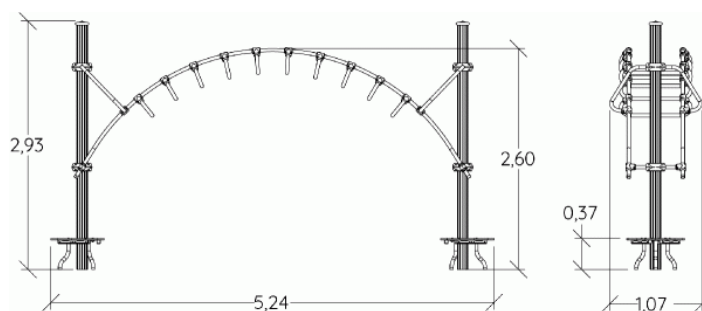

Spielwert :

3

Balancieren



Überqueren





Hangeln





Montagehinweise

WICHTIG: Die Abmessungen der Sicherheitszone sind der Montageanleitung zu entnehmen und einzuhalten.

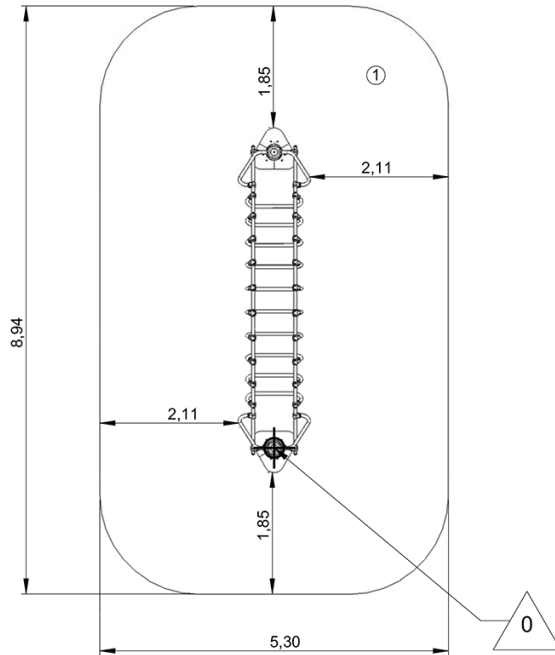
-  Fallraum (minimale normative Oberfläche)
-  Freiraum



		
1	2,4m	45,5m ²



2



02h00



0,5m³



45,5m²



133kg



54kg







 > 1,40m 4 1,4m



 1 = 5,24m
 2 = 1,09m
 3 = 2,93m



Sportliche Aspekt

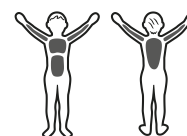

Muskelstimulation

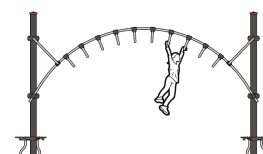

Bewegungen

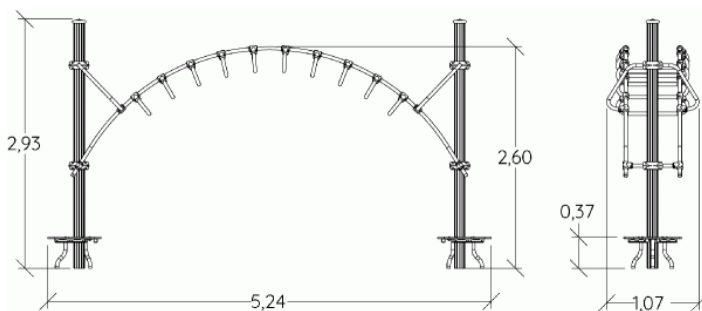

► Sportliche Aktivitäten : 3

Balancieren



Überqueren



Hangeln



 Stärkung der Muskelkraft



 Herz-Kreislauf-Training

 Gleichgewicht



 Koordination

Montagehinweise

WICHTIG: Die Abmessungen der Sicherheitszone sind der Montageanleitung zu entnehmen und einzuhalten.

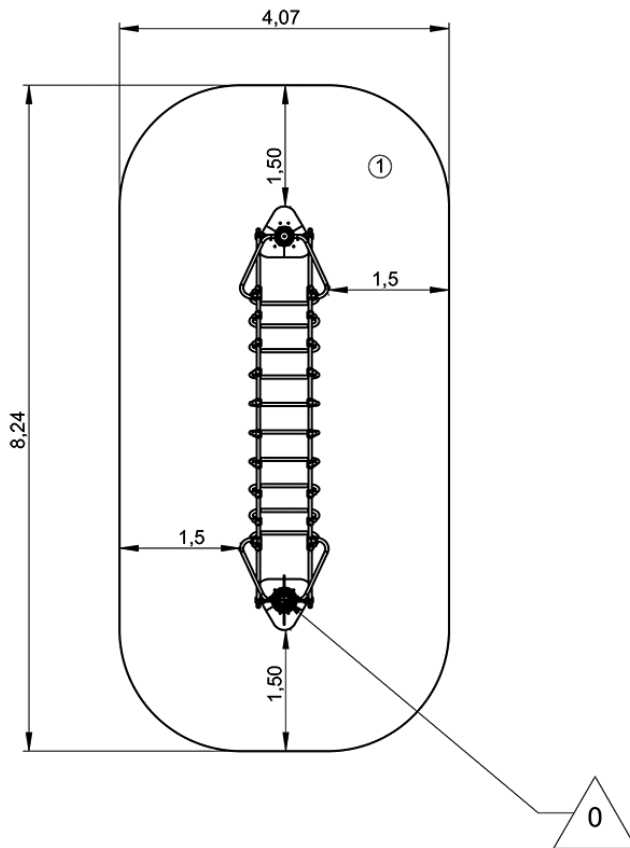
-  Fallraum (minimale normative Oberfläche)
-  Freiraum



		
1	1,4m	32m ²



2



02h00



0.5m³



45.5m²



133kg



54kg

